



# DESIGN AND CONCEPTUAL FRAMEWORK OF A UNIVERSAL SMART CHARGER WITH POGO PIN INTERFACE, USB POWER PORT, AND WIRELESS EARBUDS CHARGING

**Shreyas K R**

USN: 4VM22EE042

Department of Electrical and Electronics Engineering, Vidya Vikas Institute of Engineering and Technology, Mysore, Karnataka

## ABSTRACT

*This paper introduces the conceptual design of a universal smart charger that addresses limitations of existing charging systems. The proposed solution employs a U-shaped pogo pin-based dock that removes the need for charging cables, integrates adjustable side arms for compatibility with multiple devices, and applies smart watt-detection to deliver only the required power. To expand functionality, the design also incorporates a USB-A/USB-C port capable of adaptive power delivery for laptops and other devices, along with a wireless charging pad for accessories such as earbuds and smartwatches. Safety features include automatic cut-off at 95% state-of-charge (SoC), overload protection, and thermal monitoring, making the system suitable for public charging stations. Although the work is conceptual and does not yet include a prototype, the proposed design demonstrates significant potential to enhance charging safety, efficiency, and multi-device adaptability in public and private environments.*

**KEYWORDS :** Universal Charger, Pogo Pin, USB Smart Port, Wireless Charging, Adjustable Wattage, Automatic Power-Off, Public Charging Safety

## I. INTRODUCTION

The rapid adoption of smartphones, laptops, and wearable devices has created diverse charging requirements. Existing charging infrastructure suffers from compatibility issues, inefficient power delivery, and unsafe public charging practices. Universal chargers currently available are often bulky or fail to regulate power according to device needs, leading to overheating or overcharging.

This research proposes a multi-functional universal charger consisting of three major components:

1. Pogo pin charging dock for smart phones,
2. Smart USB port for laptops and other USB-powered devices, and
3. Wireless charging pad for low-power accessories such as ear buds.

The integration of these technologies into a wall-socket-based installation aims to create a compact, safe, and universally adaptable public charging solution.

## II. LITERATURE REVIEW

The growing diversity of electronic devices has created significant challenges in charging infrastructure. Traditional wired chargers depend on multiple connector types such as Micro-USB, USB-C, and Lightning, often resulting in compatibility issues and the need for multiple adapters [1]. Although wireless charging standards such as Qi technology have eliminated the need for cables, they still suffer from low efficiency and are mostly restricted to small devices such as smartphones and earbuds [2].

Universal chargers available today attempt to solve compatibility problems, but they often remain bulky and lack adaptive power regulation. Many models fail to include watt-detection or state-of-charge-based cut-off features, leading to risks of overheating, overcharging, and reduced battery life [3]. According to studies on smart charging systems, there is a strong need for chargers that not only integrate multiple charging interfaces but also ensure safety through intelligent power management [4].

The technical literature highlights the existence of pogo pin connectors, widely used for secure electrical contacts in compact electronic designs, but their application in universal public chargers has not been fully explored [5]. Similarly, while USB Power Delivery (USB-PD) protocols allow flexible wattage control up to 100 W, most commercial chargers do not combine this capability with wireless and pogo pin-based charging in a single compact unit [6].



### Research Gap

From the review, it is evident that there is currently no compact universal charger that integrates pogo pin charging, adaptive USB power delivery, and wireless charging within a single system. Furthermore, safety features such as SoC-based automatic termination and real-time thermal protection are rarely implemented in public charging infrastructures.

## III. PROPOSED CONCEPTUAL DESIGN

### A. U-Shaped Pogo Pin Charger

Adjustable side arms securely hold smartphones.  
Pogo pin contacts eliminate the need for cables.  
Smart watt detection ensures device-specific charging.

### B. Smart USB Port

Provides charging for laptops and other USB devices.  
Supports power delivery ranging from 20W (phones) to 65–100W (laptops).  
Compatible with USB-PD and QC protocols for adaptive fast charging.

### C. Wireless Earbuds Charging Pad

Qi-compatible low-power pad integrated at the base.  
Suitable for earbuds, smartwatches, and other accessories.

### D. Automatic Power-Off Feature

Charging terminates at 95% SoC to reduce battery stress.  
Implemented through USB-PD negotiation, BMS communication, or voltage/current estimation.

### E. Safety and Reliability

Overcurrent, overvoltage, and thermal shutdown protection.  
Timed charging cut-off for enhanced public safety.

### F. Socket Integration

Designed for wall-mounted use in bus stands, airports, malls, and railway stations.  
Compact, tamper-resistant, and suitable for heavy public usage.

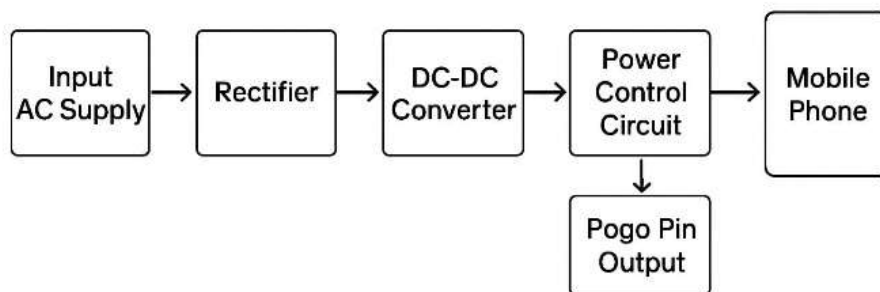

Figure 1: Block Diagram of Universal Mobile Charger

#### IV. THEORETICAL WORKING PRINCIPLE

1. User places phone in U-frame; pogo pins align with charging contacts.
2. Control unit detects power requirement via protocol negotiation or sensing.
3. Display shows wattage being delivered.
4. For laptops/other devices, the USB port supplies regulated power.
5. Earbuds can be placed on the wireless pad for charging.
6. Charging stops at 95% SoC (or time-out/thermal cutoff) for safety.
7. Safety subsystems monitor voltage, current, and temperature continuously.

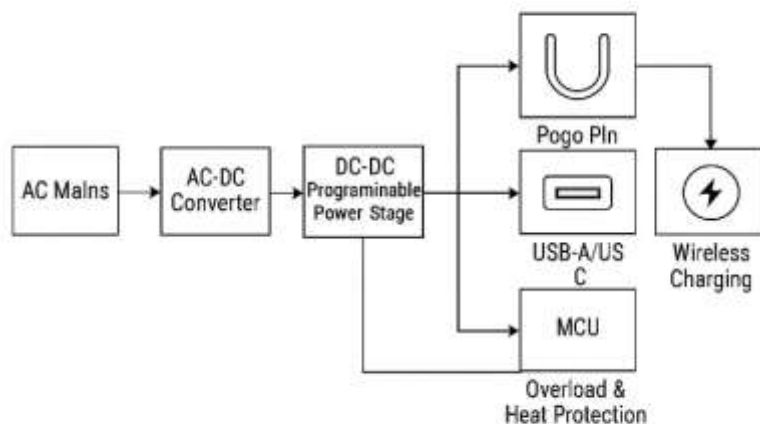

Figure 2: Smart Charging System Architecture

#### V. EXPECTED OUTCOMES

- Compatibility across smartphones, laptops, and accessories.
- Elimination of multiple charging cables.
- Safer charging with automatic 95% SoC termination.
- Compact, user-friendly charging infrastructure.
- Increased trust in public charging facilities.

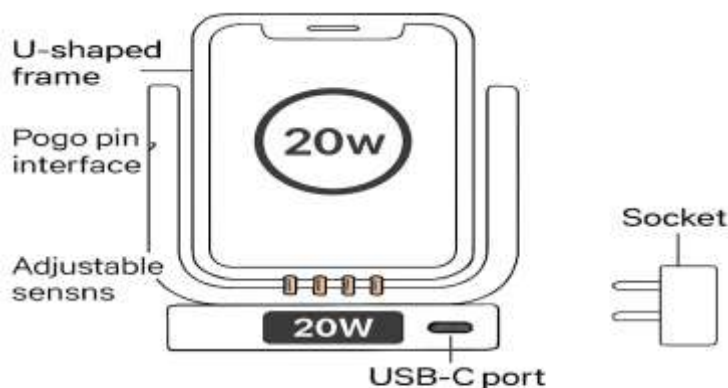

Fig. 3: Schematic of smart pogo pin mobile charge



## VI. APPLICATIONS

Public spaces: airports, railway stations, malls, bus stands.

Educational institutions and corporate offices.

Hotels, cafes, and residential use.

## VII. CONCLUSION & FUTURE SCOPE

This paper presents a conceptual design for a universal smart charger that integrates pogo pin charging, adaptive USB ports, and wireless charging into one compact system. With features such as 95% SoC-based cut-off, overload and thermal protection, and automatic watt-detection, the design addresses major shortcomings of conventional chargers and enhances safety in public charging environments.

### Key Findings:

The proposed charger is compatible with smartphones, laptops, and low-power accessories.

It eliminates the dependence on multiple charging cables by combining pogo pin, USB, and wireless interfaces.

Automatic SoC-based termination reduces battery stress and extends device life.

Compact, tamper-resistant design makes it ideal for airports, bus stands, malls, and other public spaces.

### Future Scope:

Development of a working prototype for performance validation.

Implementation of advanced USB-PD communication for precise SoC detection.

Integration of AI-based charge optimization to maximize efficiency and battery health.

Large-scale field trials in public charging stations to assess long-term reliability and user acceptance.

This universal charger concept has the potential to reduce electronic waste, improve safety, and promote convenience in both public and private charging infrastructures.



Figure 4: Universal Charging Station

## REFERENCES

1. *IEEE Standards on Mobile Charging Technologies*, 2021.
2. *Journal of Power Electronics and Applications*, Elsevier, 2020.
3. *Technical Design Data of Pogo Pins – Mill-Max Manufacturer Catalogue*.
4. *Research on Smart Charging Systems*, IEEE Xplore, 2019.
5. *USB Power Delivery (USB-PD) Specification, USB-IF*, 2021.