



# FACILITATING ROLE OF HEIS IN SHAPING THE CAREER ASPIRATION OF ENGINEERING GRADUATES

**Dr. S. A. Mohamed Ali<sup>1</sup>, Mr. Pradeep K. Ph.D.<sup>2</sup>**

<sup>1</sup>Principal, CMS Institute of Management Studies, Chinnavedampatti, Coimbatore – 641049.

<sup>2</sup>Research Scholar, CMS Academy of Management & Technology, Chinnavedampatti, Coimbatore – 641049.

Article DOI: <https://doi.org/10.36713/epra26329>

DOI No: 10.36713/epra26329

## ABSTRACT

HEIs (Higher Educational Institutions) play a role of catalyst who facilitate in achieving their career goals. HEIs pay higher attention in understanding their graduating students career plans and aspiration as strengthening employability skills of the graduating students is very crucial in the current global job market. This research paper aims to assess the perception of graduating Engineers students on the facilitating role played by their colleges in achieving their career aspiration. Data needed for the study were collected from Private Engineering Colleges functioning in Coimbatore city. The study collected data from 220 graduating students from 11 Engineering colleges. This empirical study established positive association between the engineering students understanding on the nature of career-oriented activities conduct their college and perception on college role in career guidance and career goal achievement (83.80 per cent). The graduating students highly appreciate the NAAC accredited Engineering colleges association with the industries (72 per cent) and skill development and certification programmes (60.60 per cent) conducted by placement and guidance cell functioning in their college that support them in securing well-paid and highly prestigious job during campus interview sessions.

**KEY WORDING:** Career Aspiration, Career Goal, Career Guidance, Engineering College.

## INTRODUCTION

Career Aspiration is very important criterion in human development. Engineering is diversified and more rewarding branch of study in India, the study popularity shapes career aspiration of Engineering students (Shriram, 2025). Strengthening employability skills of the graduating students is very crucial in the current global job market, especially among engineering students as they need to apply their subject knowledge practically and effectively at workplace. Thus, it can be rightly stated that preparing highly competent Engineering workforce is a challenging task for the HEIs (Malaravan and Poongodi (2021). It is strongly believed that HEIs (Higher Educational Institutions) play a role of catalyst who facilitate in achieving their career goals. HEIs pay higher attention in understanding their graduating students career plans and aspiration, as they are accountable to offer a valuable education that is fruitful to their graduates and in the progress of the educational institution (Bangari and Chaubey, 2018).

## THEME OF THE PAPER

Digitalisation and technology transformation is fast changing the employability skills and competency demanded by the Indian and global employers. As employing highly skillful and competency engineers is strategically important for the employer(s) as it is associated to the business operation, efficiency in offering their service or product manufacturing, its engineering, design, innovation, meeting customer expectation and for business sustainability (tagged, 2026). That the reason the business world

is moving towards technology-ready tomorrow and achieving this target is not possible without the highly competent Engineers. Thus, it can be rightly said that the employability competency demanded from a fresh college pass out Engineers is more based on technical skills, real world problem-solving skill, adaptability with the changing work environment, high multi-foreign language fluency, digital literacy and higher academic performance (Sharma, 2025). Job market demand of the Engineering and its related industry can be well met only by the prospective Engineers only through the right mentoring, academic knowledge exchange practices, training and interaction cum introduction with the industrial experts and activities (real-time work environment) by their college (HEI) (CADD Center, 2025). Based on the above discussion this research paper aims to assess the perception of graduating Engineers students on the facilitating role played by their colleges in achieving their career aspiration.

## LITERATURE DISCUSSION

Literature assessment supported the authors in gathering validity of information related to the study topics from the past studies.

Engineering graduates differs between those who selected their study discipline by “choice or by chance” (Geethalakshmi et al., 2025). Engineering graduating students prefer to strength their communication skill, work expertise, team work, work planning and organisation skills through attending seminars, workshops, discussion with experts /industrial person, through industrial



visits and by attending internship programmes to achieve their career pursuit (Shalini and Jegan, 2017). Final year STEM (Science, Technology, Engineering and Management students prefer to take-up those job(s) that ensure job security, job availability in the current business environment, inspiration made by parent and teachers (Meena and Parimalarani, 2023).

In the pursuits of the graduating students Engineering colleges conduct various career aspiration programmes, skill development and campus placement activities for effective employment of their pass-out graduates (Pramod et al., 2021). HEIs (Higher Educational Institutions) positively motivate their graduates in achieving their career aspirations i.e., through knowledge acquisition, developing personal skills, efficacy and competency, developing better understanding on future career prospects, job opportunities, employability, recognition motivation received from teachers, institutions, industrial experts and motivators (Bangari and Chaubey, 2018). Similarly, Colleges attempt to engagement of under graduate students in researcher activities significantly support them in boosting career aspiration, strength the confidence and personality development (Priyadarsini and Kumar, 2026). Placement officers in the colleges plays a crucial role in strengthening employability skills, knowledge on industrial needs and competency skills to be built among Engineering students (Rao, 2014)

The literatures presented above provided an understanding on the steps taken by the graduating Engineering to achieve their aspired career and the role of Engineering colleges towards strengthening the employability skills of their students. Authors realised that not many studies in the past were conducted on the study concept, research dearth provided wider scope for the conduct of this study.

## METHODOLOGY AND DESIGN OF THE STUDY

This research paper adopted both explorative and descriptive research methodology by applying qualitative (literature review) and quantitative (data collection and analysis) research technique. Data needed for the study were collected from Private Engineering Colleges functioning in Coimbatore city. The study collected data from 220 graduating students from 11 Engineering colleges. The variables used in this paper construct as abbreviated for construct of SE-Model. NCOA-Nature of Career-Oriented Activities conduct their College includes seven dimensions i.e., ACPC-Activities Conducted in the Placement Cell, INAS-Industry Association, ESDE-Entrepreneurial Skills Development, SDPC-Skill Development and Certification Programmes, PRCU-Professional Guidance, COLA-Communication Language Lab, CDCE-Career Development Cell, Graduating Engineering

students perception on role of the college in career guidance and achievement is abbreviated as PECG-Perception on College Role in Career Guidance and Career Goals Achievement and it included five dimensions: ROPC-Role of Placement Cell (placement opportunities and getting suitable placements), OPGP-Opportunities Grabbed through Placement Cell (success rate of placements (recurretes) and placement package), CAMO-Career Motivation (career preparations and opportunities for training & development programmes), INTU-Industrial Tie-Ups (strong industrial tie-ups and conduct of industrial visits) and ENIN-Expert Interaction (interaction with experts and interaction with industrial persons).

## RESULTS AND DISCUSSION

For the conduct of empirical study data were collected from 220 Engineering graduating students in Coimbatore city. The survey was conducted among equal number of male and female students (50 per cent each). Majority of the samples 86.67 per cent of the aged between 18-20 years and they are under graduates' students. Carrer aspiration of the individuals are more influenced by their medium of education, school and parents social-economic status, assessing their school background revealed that 82.73 per cent of the students studied in the English medium school and 87.27 per cent of the students' studies in the Tamil Nadu state board education system. Social status of the students revealed that 70.46 per cent of the samples belong to the middle-income family, 49.09 per cent of the students' parents are private sector employee and 89.55 per cent of the students' family is depended on the single income source.

In relevance to the above discussion, it has been Inferred that 86.40 per cent of the Engineering students very well understand that their college placement cell conducts number of placement and skill enhancement activities. And 79.40 per cent of the samples claim that their college has CDC (Career Development Cell) like: pre-placement talks, aptitude test, written test, group discussion etc. Graduating Engineering students highly appreciates the career preparation (skills) inculcated by their college's placement cell (87 per cent), conduct of various technical and non-training & development programmes and placement opportunities offered by the placement cell (77 per cent).

Drawing relevance to the literatures discussion made above the SE-Model is constructed. The SEM aimed to measure association between engineering students understanding on the nature of career-oriented activities conduct their college and perception on college role in career guidance and career goal achievement.



**EXHIBIT: 1**  
**CONFIRMATORY FACTOR ANALYSIS**  
**ENGINEERING STUDENTS UNDERSTANDING ON THE NATURE OF CAREER-ORIENTED ACTIVITIES CONDUCT**  
**IN THEIR COLLEGE VS THEIR PERCEPTION ON THE ROLE OF PLACEMENT CELL**

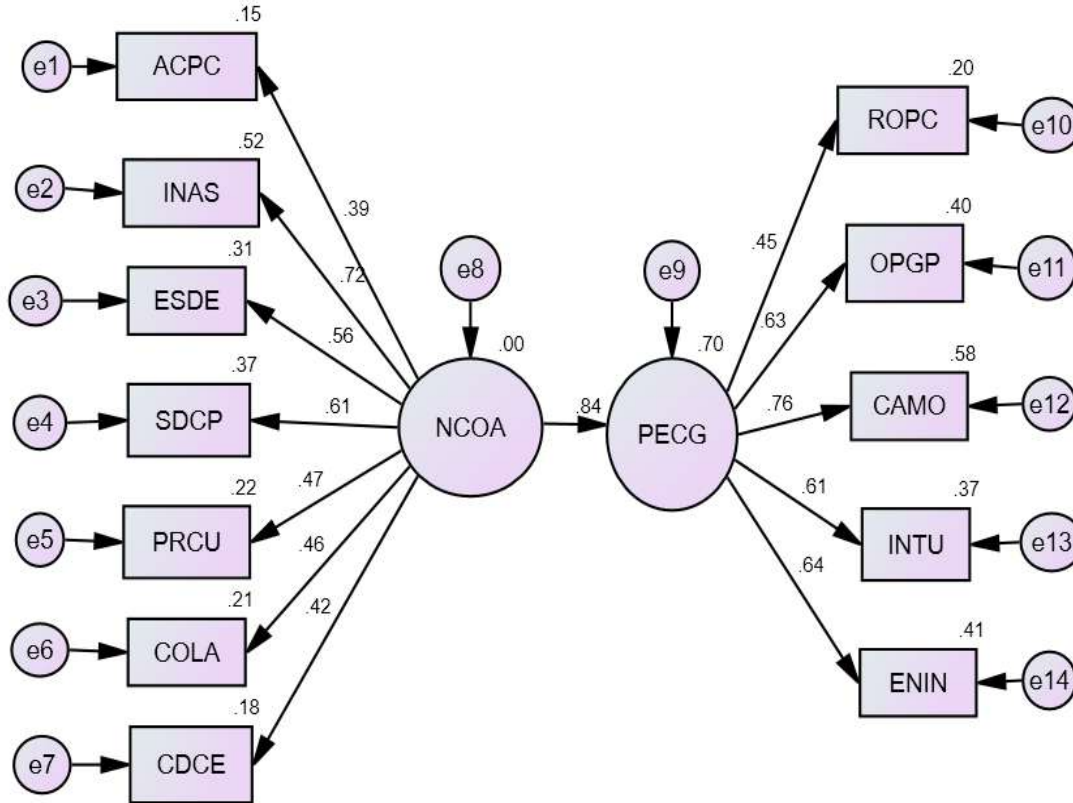

For hypothesis testing, the proposed model with all measurement items from the CFA was estimated. The results revealed acceptable fit indices of the model;  $\chi^2 = 149.512$ ,  $p < 0.001$ ,

degrees of freedom = 53; parsimony fit ( $\chi^2/df$ ) = 2.821; GFI = 0.906; AGFI = 0.915; CFI = 0.985; IFI = 0.990; RMSEA = 0.004.

**TABLE: 1**  
**STRUCTURAL MODEL RESULTS**

Hypothesis	Path			Standardized Estimates	C.R	Relationship
Association between Engineering students understanding on the nature of career-oriented activities conduct their college and perception on college role in career guidance and career goal achievement	NCOA	→	PECG	.838	4.024	Significant

Association between engineering students understanding on the nature of career-oriented activities conduct their college and perception on college role in career guidance and career goal

achievement: vs NCOA vs PECG ( $\beta=.838$ ,  $p=.000$ ) is positively correlated and found to be significant at 83.80 per cent.



**TABLE: 2**  
**STRUCTURAL MODEL RESULTS**

Hypothesis	Path			Standardized Estimates	C.R	Relationship
Intercorrelation correlation of engineering students understanding on the nature of career-oriented activities conduct their college	NCOA	--->	CDCE	.420	4.852	Significant
	NCOA	--->	COLA	.459	4.610	Significant
	NCOA	--->	PRCU	.474	4.746	Significant
	NCOA	--->	SDCP	.606	5.162	Significant
	NCOA	--->	ESDE	.560	4.929	Significant
	NCOA	--->	INAS	.720	4.982	Significant
	NCOA	--->	ACPC	.385	3.866	Significant
Intercorrelation correlation of perception on college role in career guidance and career goal achievement	PECG	--->	ROPC	.452	5.781	Significant
	PECG	--->	OPGP	.635	5.731	Significant
	PECG	--->	CAMO	.763	6.039	Significant
	PECG	--->	INTU	.608	5.584	Significant
	PECG	--->	ENIN	.642	5.602	Significant

Intercorrelation correlation of engineering students understanding on the nature of career-oriented activities conduct their college as: CDCE vs NCOA ( $\beta=.420$ ,  $p=.000$ ), COLA vs NCOA ( $\beta=.459$ ,  $p=.000$ ), PRCU vs NCOA ( $\beta=.474$ ,  $p=.000$ ), SDCP vs NCOA ( $\beta=.606$ ,  $p=.000$ ), ESDE vs NCOA ( $\beta=.560$ ,  $p=.000$ ), INAS vs NCOA ( $\beta=.720$ ,  $p=.000$ ) and ACPC vs NCOA ( $\beta=.385$ ,  $p=.000$ ) are positively correlated and found to be significant. Perception on college role in career guidance and career goal achievement: ROPC vs PECG ( $\beta=.452$ ,  $p=.000$ ), OPGP vs PECG ( $\beta=.635$ ,  $p=.000$ ), CAMO vs PECG ( $\beta=.763$ ,  $p=.000$ ), INTU vs PECG ( $\beta=.608$ ,  $p=.000$ ) and ENIN vs PECG ( $\beta=.642$ ,  $p=.000$ ) are positively correlated and found to be significant. The hypothesis framed stands accepted.

## FINDINGS AND CONCLUSION

In the path of career aspiration and its achievement journey of graduation students, the role and contribution of HEIs are indispensable. This empirical study established positive association between the engineering students understanding on the nature of career-oriented activities conduct their college and perception on college role in career guidance and career goal achievement (83.80 per cent). The graduating students highly appreciate the NAAC accredited Engineering colleges association with the industries (72 per cent) and skill development and certification programmes (60.60 per cent) conducted by placement and guidance cell functioning in their college that support them in securing well-paid and highly prestigious job during campus interview sessions. The students have also appreciated the Career Motivation i.e., career preparations and opportunities for training & development programmes conducted in their college. The authors found that still date there exists gap between employment motivation and opportunities offered by the HEIs and success rate of the students in achieving aspirant, well paid and prestigious job. Thus, the HEIs are suggested to focus more on understanding the aspiration of their graduating candidates and offer tailor made skill enhancement, motivation and training programmes for individual students, that could

support them in gaining good job, at the same time the institution could earn high reputation and respect in the society.

## REFERENCE

- Geethalakshmi.P. M, Vinod .V. Thomas and Sumam David (2025), *Choosing Engineering Education: Understanding The Motives of Indian Young Women-A Narrative Inquiry*, *European Journal of Engineering Education*, Taylor & Francis, <https://www.tandfonline.com/doi/epdf/10.1080/03043797.2025.2606909?needAccess=true>.
- Hiring Strategies for Top Engineering Roles in Demand for 2026*, tagged, 19<sup>th</sup> January, 2026, <https://taggd.in/blogs/hiring-strategies-for-engineering-roles-in-demand/>.
- How to Make Engineers Employable: A Complete Guide*, CADD Center, 6<sup>th</sup> November, 2025, <https://caddcentre.com/blog/how-to-make-engineers-employable/>
- Joly Shalini. N and Jegan. K (2017), *Employability Skills - Perception of the Final Year Engineering Students at South Tamilnadu, India*, *SSRG International Journal of Economics and Management Studies (SSRG - IJEMS)*, Volume.No.4, Issue.No.11, ISSN: 2393-9125, PP:31-35, November.
- Kirupa Priyadarsini .M and Pavan Kumar.S (2026), *From Campus to Career: The Influence of Undergraduate Research on Aspirations, Growth, and Research Mindset in Engineering Education*, *Journal of Engineering Education Transformations*, Volume.No.39, Special Issue.No.2, ISSN 2394-1707 (E), PP: 279-287, January.
- Malaravan. M and Poongodi. P (2021), *The Impact of Employability Skills in Career Opportunities Among Engineering Graduates*, *Inspira- Journal of Modern Management & Entrepreneurship (JMME)*, , Volume.No.11, Issue.No.3, ISSN: 2231-167X, PP:1-4, July-September.
- Monika Bangari and Dhani Shanker Chaubey (2018), *Convergence of Motives for Higher Education: A Study on the Aspiring Students in India*, *Journal of Entrepreneurship Education*, Vol.21(1), PP:1-11.
- Nipun Sharma (2025), *Why are so Many of India's 1.5 million Fresh Engineers Every Year Unemployable?*, *India Forbes*, 13<sup>th</sup> November.



9. Rao .M.S (2014), *Enhancing Employability in Engineering and Management Students Through Soft Skills, Industrial and Commercial Training*, Volume.No.46, Issue.No. 1, ISSN" 0019-7858(P), ISSN:1758-5767, PP:42-48, January.
10. Rathi Meena .M and Parimalarani (2023), *Career Preference of Graduates in Tamilnadu: An Empirical Study*, Dogo Rangsang Research Journal, Volume.No.13, Issue.3, No.4, ISSN: 2347-7180, PP: 129-138, March.
11. *Reasons Why Engineering is One of the Best Career Paths for Students*, Shriram, 10<sup>th</sup> February, 2025, <https://srgoc.org/reason-why-engineering-is-one-of-the-best-career-paths-for-students/>.
12. Shahabadkar Pramod, Joshi Ajinkya, Lele Vaishali and Patil Vilas (2021), *Understanding Aspirations of First Year Undergraduate Engineering Students*, Journal of Engineering Education Transformations, Volume.No.34, Special issue, ISSN 2394-1707 (E), PP:86-92, January.